

LIGHTNING

OPERATIONS AND MAINTENANCE MANUAL





TABLE OF CONTENTS

LIGHTNING

SECTION I	GENERAL DESCRIPTION
SECTION II	SPECIFICATIONS
SECTION III	SAFETY AND PRECAUTIONS
SECTION IV	INSTRUMENTS AND CONTROLS
SECTION V	START-UP AND BREAK-IN
SECTION VI	MACHINE OPERATION
SECTION VII	PREVENTIVE MAINTAINANCE
SECTION VIII	ENGINE
SECTION IX	FRAME & COWLINGS
SECTION X	HYD AND DRIVE COMPONENTS
SECTION XI	VALVE JOYSTICK ASSEMBLY AND CABLES



**OPERATIONS
AND
MAINTENANCE MANUAL**

**CUSTOMER
SERIAL NUMBER
DATE SHIPPED**



SECTION I

GENERAL DESCRIPTION Lightning

The *Lightning* is operated by a propane-powered engine, driving a tandem hydrostatic pump system, creating a (skid-steer) zero turn radius drive train. Surface covering and coatings are removed by lowering a weighted blade onto the surface and moving forward under a high torque drive system. The surface coating is removed by a flexible sharpened blade conforming to the floor surface, with the weight of the machine holding the blade firmly to the floor. The weight does not allow the blade to lift or ride over well-adhered surface coating material, thus lifting the off the floor coating.

After layers of carpet or laminates are removed the machine can be connected to a grinder or slicer attachment to either clean up adhesives or remove stubborn coatings.



SECTION II

SPECIFICATIONS

Weight	2120 lbs
Removable weight	516 lbs
Height	51 inches
Width	26 inches
Length	51 ½ inches
Engine	25 HP Kohler Propane
Max Ground Speed	320 ft per min.



SAFETY

WARNING



CARBON MONOXIDE can cause severe nausea, fainting or death. Do not operate engine in closed or confined area without proper ventilation.



SECTION III SAFETY AND PRECAUTIONS

Before operating the **Lightning** please read the entire operation and safety manual with complete understanding of the safety section. If you have any questions on safety and precautions please call 1-866-636-7763.

There are several advantages to an effective safety program which include: lower operating costs, lower workman compensations, less work time lost, high employee morale, and less problems. No one can work safely without knowing what precautions to take to insure personal safety. Operators must know what equipment to wear, which job practices are safe and which are not, and must be aware of what hazards are possible in the work area. A regular schedule of Preventive Maintenance on your equipment is the best protection against unpleasant surprises that slow production and sometimes result in injuries. Here are a few suggested safety tips.

1. The first step before any maintenance or inspection takes place should be to stop the engine and disconnect the battery terminals.
2. Wear proper eye and ear protection and heavy duty work gloves at all times.
3. Practice good Preventive Maintenance.
4. Practice good housekeeping.
5. Allow the **Lightning** to come to a complete stop, turn off engine, and chock rear wheels before performing any maintenance procedures.
6. Replace worn parts when necessary.
7. Do not reach into blade or control arm areas while machine is in operation.
8. Do not attempt to open any access door until the machine has come to a complete stop and the engine and propane is turned off.
9. Be sure all electrical inspections or changes are done by a qualified electrician.
10. Loose surface coating can cause dangerous footing. Always be alert and careful.
11. After replacing parts be sure all tools used are removed from the machine. Be sure all bolts and nuts are tightened. The loose connection of a rotating part could cause the part to fly off with explosive force, causing serious damage to the equipment and possible injury to the operator.
12. Always lower blade to the ground when the machine is unoccupied by the operator. Serious bodily injury may result if arms are not in the lowered position when not occupied.
13. Never allow unauthorized personnel or the general public into the work area.
14. The work area should be barricaded off to adequately keep all untrained persons out of the work site. If an unauthorized person enters the work area, stop the machine immediately and do not restart the machinery until they have left the work area.
15. Always allow a 200-foot buffer safety zone around all surface preparation activity.
16. Always run the **Lightning** in a well-ventilated area, with an approved OSHA air-monitoring system in place at all times.



17. Read and obey all safety labels placed on the machinery at all times. If safety labels have been destroyed or removed call 1-866-636-7763 for free replacement prior to operating the machinery.
18. The **Lightning** is **not a toy**. All operators must be over 18 years of age and must have read and reviewed the safety and procedures manual before operating the machinery.
19. The **Lightning** is designed for surface preparation *ONLY*. It is not intended for towing, pushing or any other procedure not described in this manual.
20. Propane systems should be checked and documented twice yearly by a certified propane professional for leaks or damaged parts. If a propane leak is detected leave the machine immediately and seek assistance from propane professional. Do not use or restart machinery until it is determined safe.
21. Horseplay and or high speed cornering is not allowed with this machine and could cause rollover resulting in injury or death.
22. No smoking or open flame is allowed while machinery is running or within 50 feet of the machine.
23. Operator must be sober and not under the influence of drugs or medication and under full control of all bodily senses while operating this or any machinery.
24. When transporting the **Lightning**, it is recommended to use a low bed tilt trailer. This procedure insures the wheels do not leave a stable surface.
25. All **Lightning** operators must receive safety training before performing any functions with the machine. **OEM Products** offers a free 8- hour safety, maintenance and orientation seminar at its facility in Oklahoma City, OK.
New owners and operators are advised to call 1-866-636-7763 for an appointment.



SECTION IV

Instruments and Controls

View # 1 - Top view of Lightning machine

View # 2 - Left side view of Lightning machine

View #3 - Right side view of Lightning machine

View #4 - Front view of Lightning machine



View #1 Top View

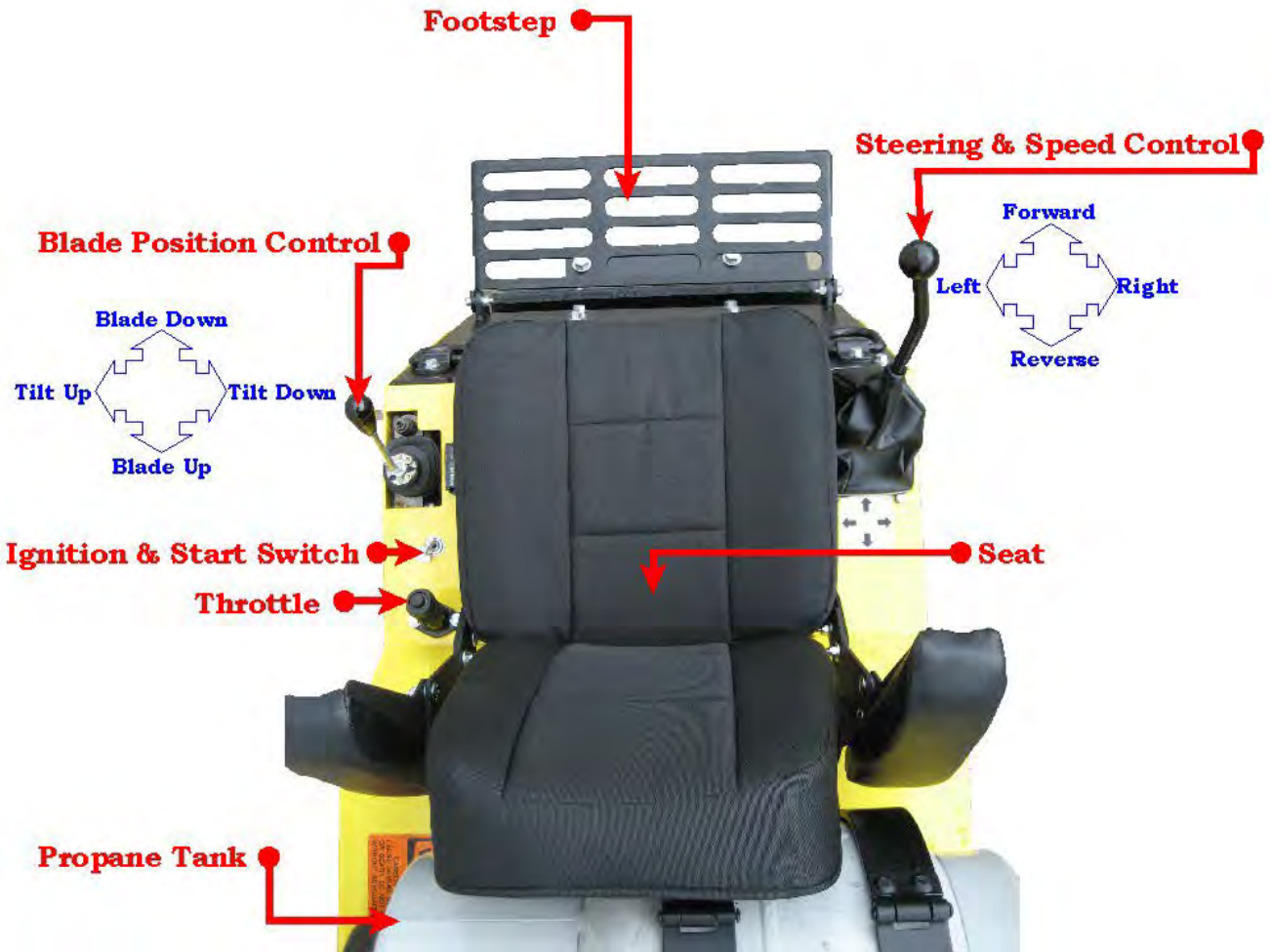

VIEW #2 LEFT SIDE DETAIL

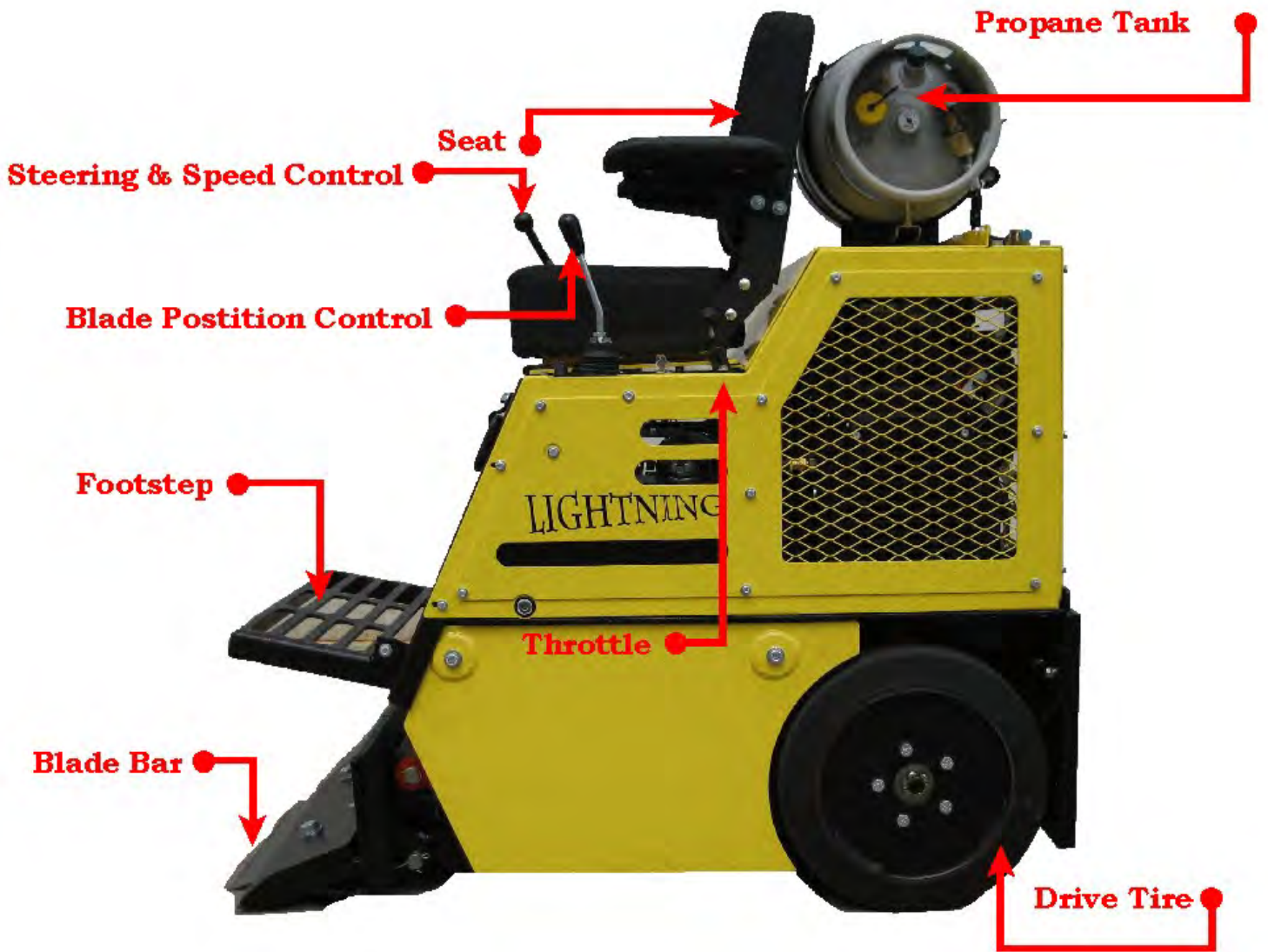

VIEW #3
RIGHT SIDE DETAIL





SECTION V
Lightning
START-UP AND BREAK-IN



The **Lightning** has been safety tested and run at our factory prior to shipping. All fluid levels have been topped off; however, no propane has been added to the tanks for safety shipment purposes. Before running the **Lightning** please check the following items that may have shifted or changed during shipping.

1. Raise engine covers and check oil level.
2. Check air cleaner filter element for snug fit.
3. All battery cable connections are snug.
4. Inspect for major hydraulic oil leaks. Snug hydraulic fittings using two wrenches. Use caution not to over tighten.
5. Fill propane tank.
6. Mount propane bottle in brackets, be sure bracket alignment pin corresponds with alignment slot on bottle.
7. Attach propane hose to liquid side of bottle by attaching to the handle valve. Snug fit the female connector attached to hose and slowly turn valve on. You should hear gas briefly enter the propane hose. Immediately check for propane leaks with soapy water solution. If leak persists after retightening the knurled female connector: **STOP**, turn off the bottle at valve and seek assistance from certified propane professional. Serious damage and or an explosion could occur.
8. Check lug bolts for tightness, torque 85-100 lbs.
9. Return all engine guards to proper position.
10. You are now ready to start the engine.
11. Crank the engine by turning the key in the on position. The engine will crank for 3 to 5 seconds while the propane enter the carburetor. If the engine does not start, turn the key off, wait 1 minute and try again. If again unsuccessful, check propane valve to be sure it is open. If still unsuccessful turn off propane valve and seek assistance or call 1-866-636-7763.
12. Once the engine is warming and running, and the operator is safely in the seat, the machine can be driven.

Please turn to Section VI for Machinery Operation.

NEW MACHINE BREAK-IN

Since the Lightning is a very low maintenance and user-friendly machine, the only break-in is for the Kohler engine. Please refer to the owners manual, included is the manual and the maintenance schedule found inside the air cleaner plastic cover supplied by Kohler.

SECTION VI MACHINERY OPERATION

Before reading the machinery operation section, new operators should familiarize themselves with the 3 diagrams depicting the TOP, LEFT, and RIGHT views of machine. These drawings show the activation of all moving parts of the Lightning

1. To move the machine: Using the right hand, slowly move the shifter lever in the desired direction. Forward and left moves the machine to the left, backward and



Right reverses the machine to the right. It is just that simple to drive. Speed is controlled by amount of movement on the joy stick and also by moving travel Speed lever.

2. The left joystick lever is used to position the blade to the surface. Moving the lever forward and backward moves the blade up and down. Left and right movement changes the blade pitch.
3. Throttle control is on the left side of the seat, taking the unit from idle to 3400 RPM. The most optimum speed is 2600 to 3200 RPM. To change RPM of engine turn throttle knob clockwise to lower RPM and counterclockwise to raise RPM.
4. A cooling fan will run behind the seat when engine is running to keep hydraulic oil cool.
5. Hydraulic reservoir is accessed by removing right cowling and removing fill cap.
6. To change scraping blades: Stop engine. Loosen the set bolt at the rear of the Blade holder block using a $\frac{3}{4}$ " open-end wrench. Slide the dull blade out and Insert a new blade up against the shim stop. Retighten the set bolt and raise the control arms to remove wooden block. Lower control arms and resume scraping. The large 1 1/8" blade holder bolt should not need to be more that hand tight. With a little practice you should be able to change blades in 15 seconds. Dull blades can be resharpened and reused many times.

SEE DRAWING OF BLADE CHANGE PROCEDURE

3. Operators should lower the blade by pressing the left hand lever forward each time they get off the machine. This safety practice eliminates possible bodily injury from lowering the blade by unauthorized operators.
7. The transport caster should not be in contact with the floor while scraping. It will lift off the floor when blade is lowered. Caster contact with the floor while scraping will negatively affect scraper productivity and steering.
4. Do not transport machine with front of machine off the surface of floor higher than 1/2" or irreparable damage to lift cylinder will result.

See illustration of correct scraping procedures.



Blade Installation

TRANSPORT DOLLEY
INSTALLED



TILE REMOVAL BLADE

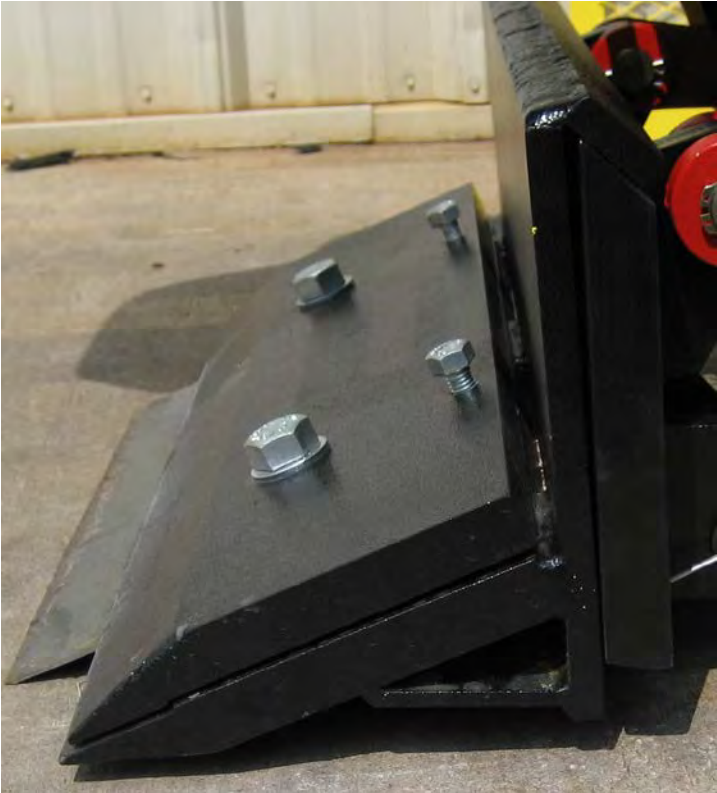

Before performing blade changes park machine on solid level floor.

1. Start engine and use left control lever to raise blade bar off the floor approximately 3 inches.
2. Turn off engine.
3. Loosen two “pinch” bolts with a $\frac{3}{4}$ ” wrench (turn counter-clockwise).
4. Loosen two “hold down” bolts with a 1-1/8” wrench (turn counter-clockwise)
5. Carefully remove old blade and slide new blade into the blade bar. Install in the center of blade bar (left to right). Ensure blade is pushed back to the “blade stop”. Do not handle blade edge! It is extremely sharp!
6. Hand tighten (hold down bolts)
7. Using $\frac{3}{4}$ ” wrench tighten “pinch” bolts.

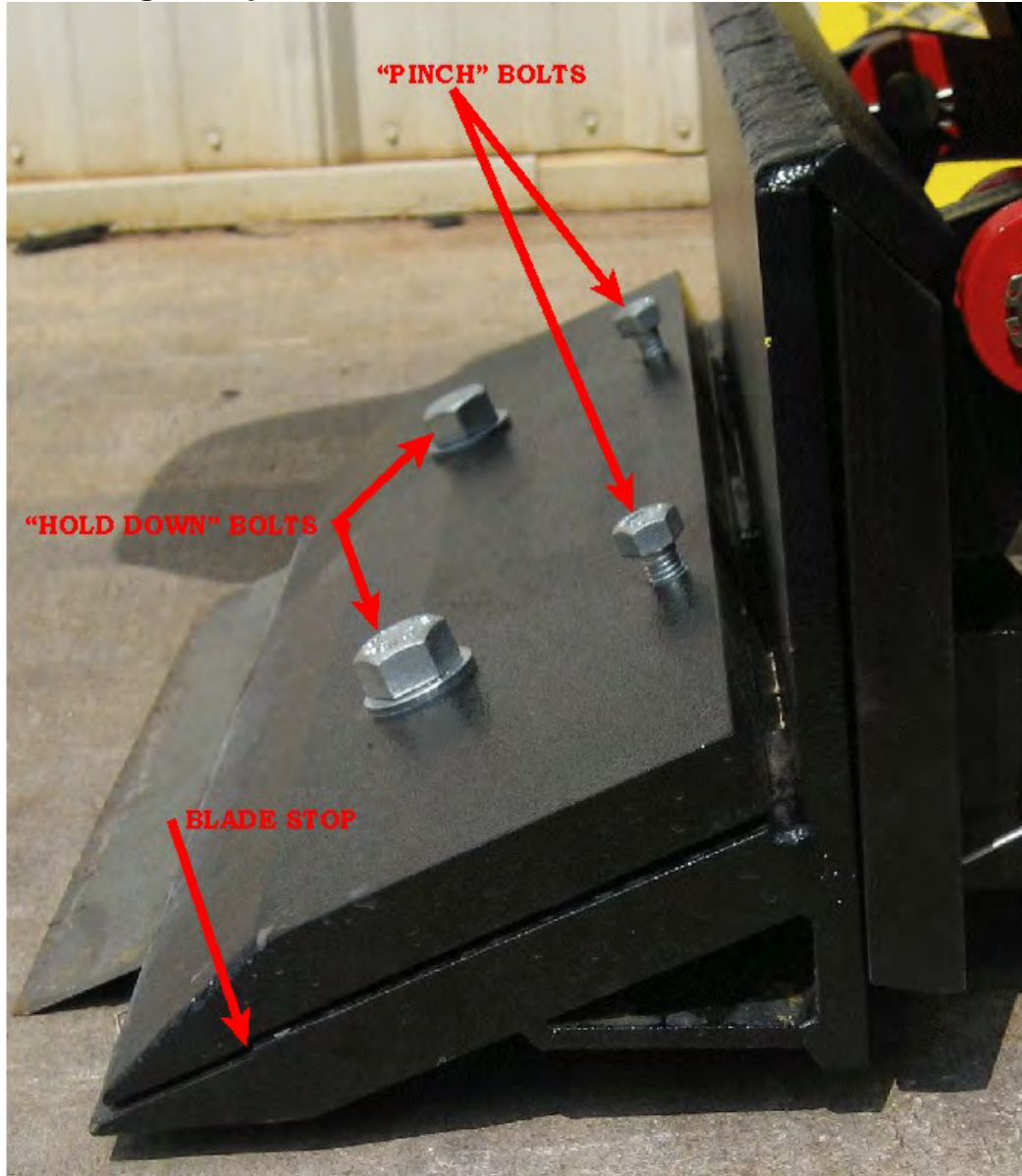

BLADE POSITIONING

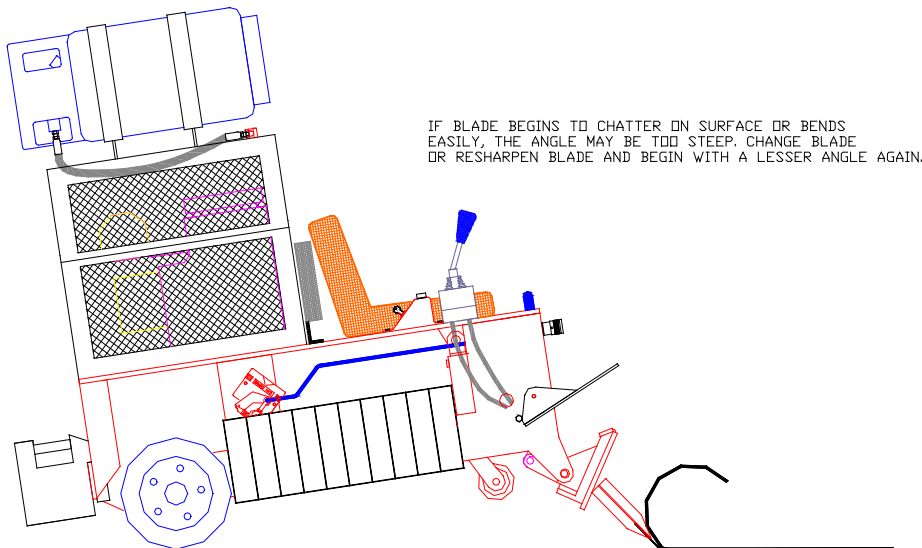
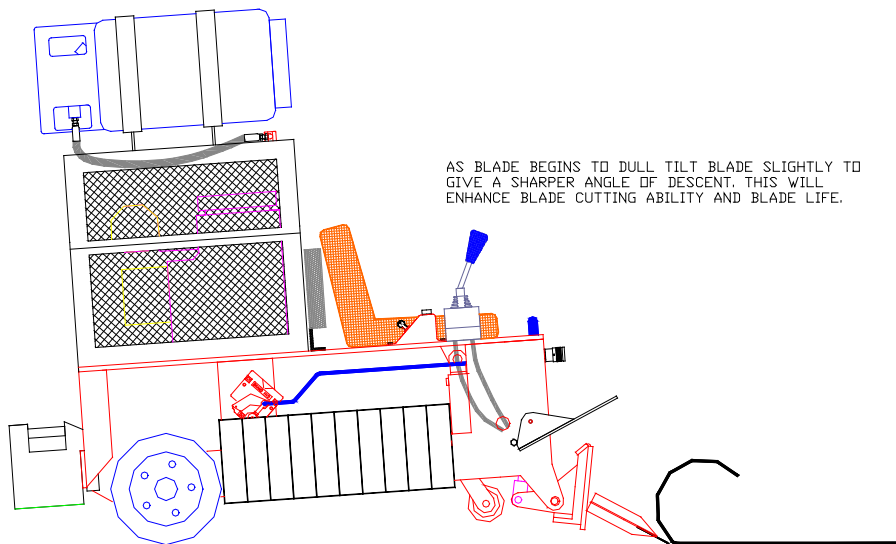
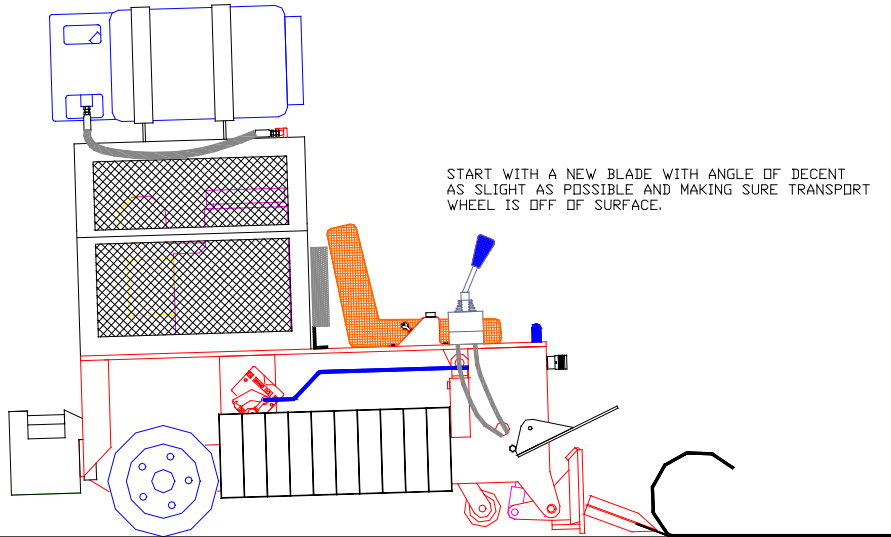

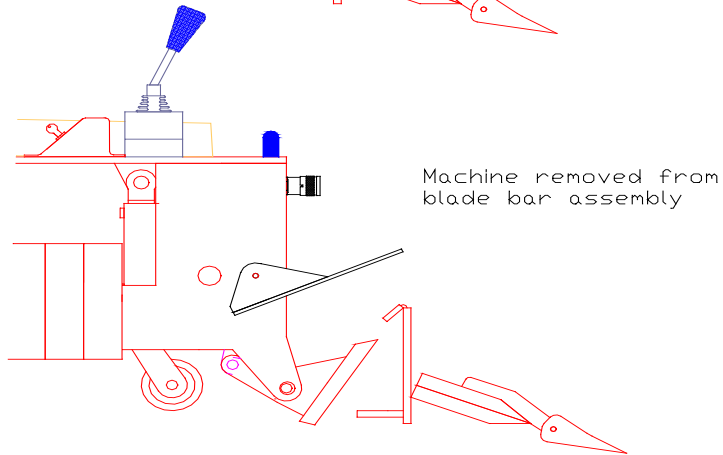
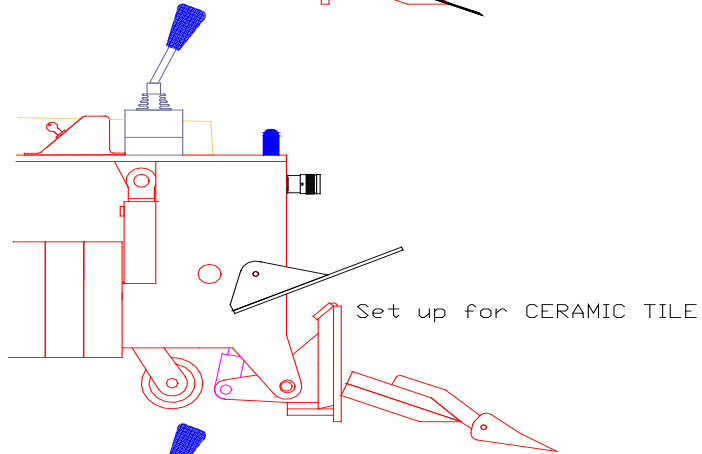
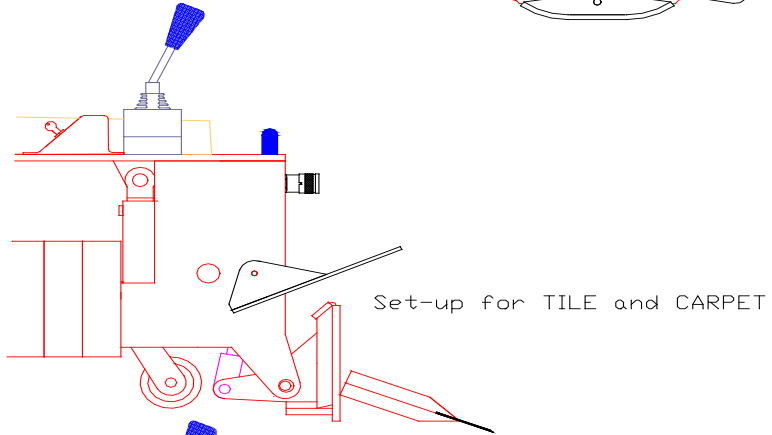
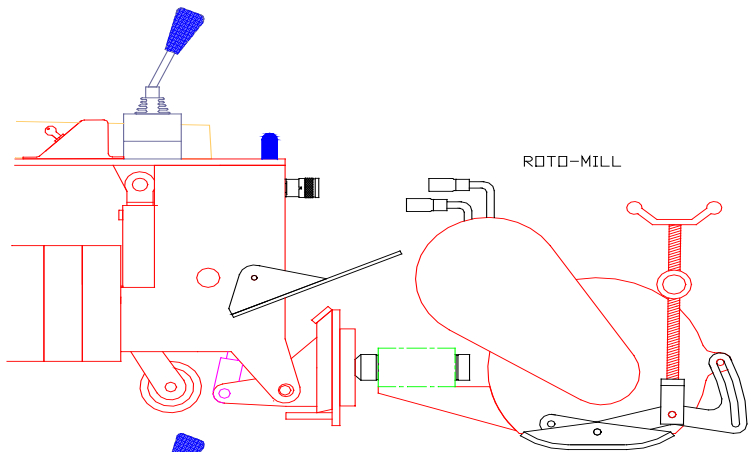

SECTION VII

Preventative Maintenance

FOLLOW KOHLER SUGGESTED SCHEDULE FOR ENGINE MAINTAINANCE

1. DAILY MAINTENANCE

- CHECK HYDRAULIC OIL
- INSPECT FOR HYDRAULIC OIL LEAKS
- INSPECT FOR PROPANE SYSTEM LEAKS
- SERVICE ENGINE AIR CLEANER
- RETORQUE WHEEL LUG BOLTS

1. 100 HR MAINTENANCE

- GREASE CASTER BEARINGS, BLADE ARM PIVOTS, STEERING LINKAGE ROD ENDS
- INSPECT ALL BOLTS AND NUTS AND TIGHTEN IF NEEDED
- CHANGE ENGINE OIL AND FILTER (5W-30)
- INSPECT BELTS FOR CRACKING AND ENSURE CORRECT TENSION

2. 400 HR MAINTAINANCE

- CHANGE HYDRAULIC OIL WITH: Mobil 1 15-50 Motor Oil
- CHANGE HYDRAULIC OIL FILTERS



SECTION VIII
ENGINE COMPONENTS LIST

KEY	DESCRIPTION	QTY	PART NUMBER
1	ENGINE	1	LE-001
2	GASKET, BREATHER		LE-002
3	ENGINE DIPSTICK TUB KIT		LE-003
4	COOLING FAN		LE-004
5	ENGINE FLYWHEEL		LE-005
6	FLYWHEEL FAN		LE-006
7	STATOR ASSEMBLY		LE-007
8	THROTTLE LINKAGE ASSEMBLY		LE-008
9	AIR CLEANER COVER		LE-009
10	EINGINE AIR FILTER		LE-010
11	PRE-CLEANER FOR AIR FILTER		LE-011
12	ENGINE OIL FILTER		LE-012
13	OIL PRESSURE SWITCH		LE-013
14	KIT, GOVERNOR GEAR W/PIN		LE-014
15	EXHAUST PURIFIER		LE-015
2	IGNITION SWITCH	1	LE-016
	WIRING HARNESS		LE-017
	ENGINE TACHOMETER		LE-018
	MUFFLER BRACKET		LE-019
	ENGINE SPARK PLUG		LE-020
3	ENGINE STARTER	1	LE-021
	EXHAUST GASKET		LE-022
4	IDLER PULLEY	1	LE-023
5	Set of pump drive belts (double row 3VX-500 and 3VX-300)		LE-024
	ENGINE DRIVE PULLEY 2GR 3V 5.0	1 (2pc)	LE-025
	1/2" QD BUSHING		LE-026
	1-1/8" QD BUSHING		LE-027
	BATTERY		LE-028
	BLACK (-) BATTERY CABLE 16"		LE-029
	RED (+) BATTERY CABLE 36"		LE-030
7	BATTERY CABLE LUGS 1/4" (2 ea)		LE-031
	BATTERY CABLE LUGS 5/16" (2 ea)		LE-032
8	BELT TENSIONER ASSEMBLY		LE-033
9	BELT TENSIONER BACK PLATE		LE-034
	BELT TENSIONER CONTROL ARM		LE-035
	BELT TENSIONER PULLEY ARM		LE-036
	BELT TENSIONER LINKAGE ROD 8"		LE-037



BELT TENSIONER LK ROD ENDS
ENGINE OIL CASE DRAIN HOSE
IGNITION COIL
SAM MODULE
IGNITION KEYS
IDLER PULLEY SPACER

LE-038
LE-039
LE-040
LE-041
LE-042
LE-043
LE-044

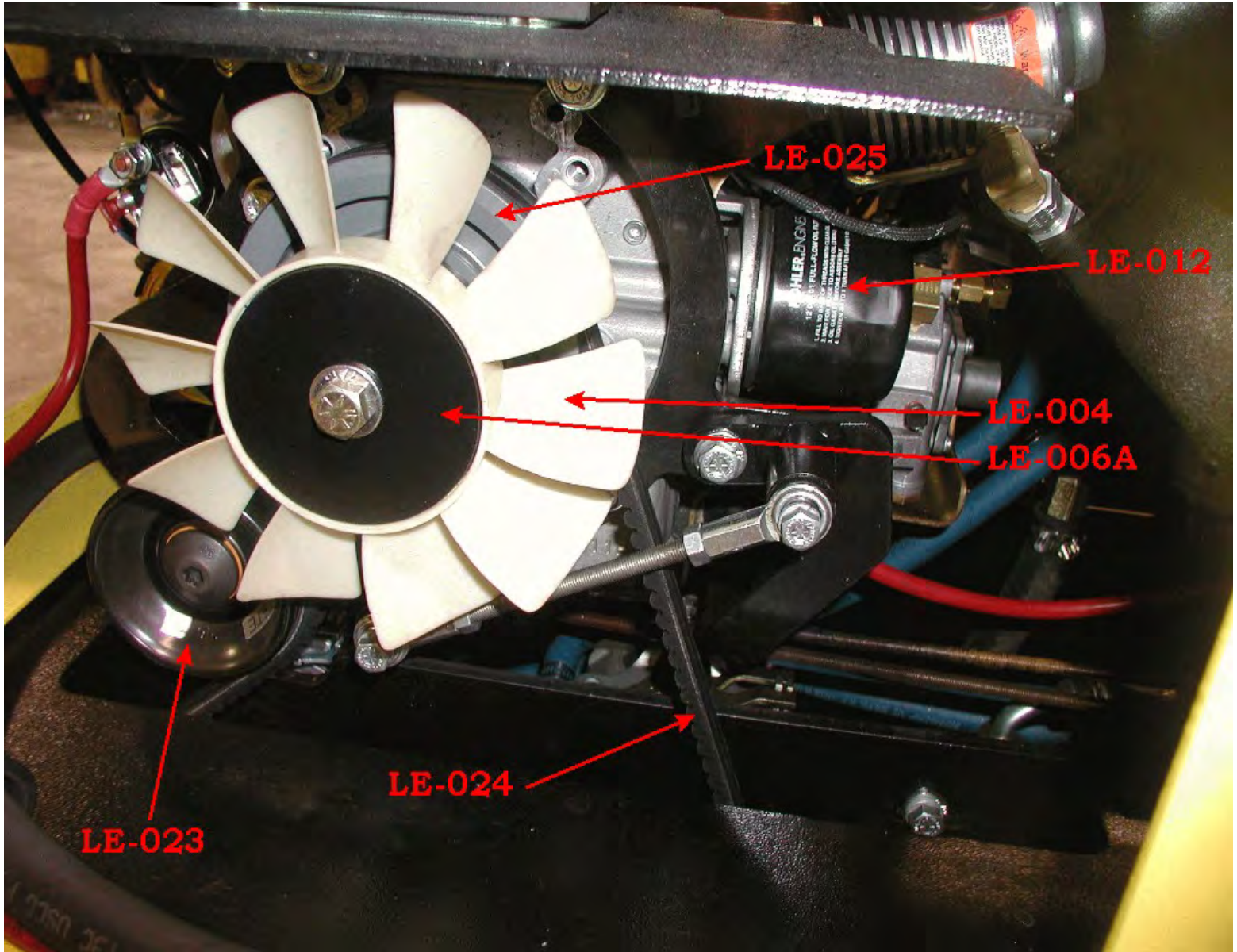

SECTION IX

FRAME AND COWLINGS

KEY DESCRIPTION	QTY	PART NUMBER
1. TIRES – BLACK	2	LFC-001
2. TIRES (NON-MARKING)	2	LFC-001B
3. LUG BOLTS	10	LFC-002
4. WHEEL HUB	2	LFC-003
5. 1" 2-BOLT FLANGE BEARING	2	LFC-004
6. CASTER ASSEMBLY	1	LFC-005
7. BATTERY HOLD DOWN BRACKET		LFC-006
8. WEIGHTS		LFC-007
9. TRANSPORT DOLLY		LFC-008
10. BLADE BAR (24") ASSEMBLY		LFC-009
11. BLADE BAR (24") TOP		LFC-010
12. BLADE BAR (24") BOTTOM		LFC-011
13. BLADE CLAMP BOLTS		LFC-012
14. BLADE BAR MOUNTING PLATE		LFC-013
15. BLADE BAR PIVOT PINS W/ COTTER KEY		LFC-014
16. SEAT	1	LFC-015
17. SEAT MOUNTING PLATE		LFC-016
18. SEAT MOUNTING PLATE HINGE		LFC-017
19. FRONT PLATE		LFC-018
20. FOOTREST		LFC-019
21. D-RING FOR LIGHTNING	3	LFC-020
22. REAR PLATE		LFC-021
23. REAR COWLING		LFC-022
24. HING, TOP COWLING		LFC-023
25. TOP COWLING		LFC-024
26. FRAME, RIGHT SIDE		LFC-025
27. COWLING, RIGHT SIDE		LFC-026
28. WEIGHT COVER, RIGHT SIDE		LFC-027
29. FRAME –LEFT SIDE		LFC-028
30. COWLING - LEFT SIDE		LFC-029
31. WEIGHT COVER, LEFT SIDE		LFC-030
32. FRAME- RIGHT SIDE		LFC-031
33. LEFT ARM		LFC-032
34. CROSSOVER ARM		LFC-033
35. CROSSOVER ARM PIN		LFC-034
36. RIGHT ARM		LFC-035
37. THROTTLE CABLE HEAT SHIELD		LFC-036
38. SCRUBBER HEAT SHIELD		LFC-037
39. FIRE SLEEVE, THROTTLE CABLE		LFC-038



40. THROTTLE CABLE	1	LFC-039
41. CASTER "WHEEL ONLY"	1	LFC-040
42. BATTERY HOLD DOWN BOLTS		LFC-041
43. HYDRAULIC COOLER MOUNTING PLATE		LFC-042
44. BLADE BAR (8") ASSEMBLY		LFC-043
45. BLADE BAR (8") TOP ONLY		LFC-044
46. BLADE BAR (8") BOTTOM ONLY		LFC-045
47. BLADE ARM SPACER		LFC-046
48. BLADE ARM RETAINING WASHER		LFC-047
49. WHEEL SCRAPER		LFC-048
50. LATCH, COWLING	1	LFC-063



SECTION X
Hydraulic components parts list

KEY	DESCRIPTION	QTY	PART NUMBER
	GEAR PUMP		LH-003
	HYDRAULIC TANK		LH-007
	TANK FILLER CAP		LH-008
	LIFT/TILT CYLINDER		LH-014
	LIFT/TILT CYLINDER CLEVIS		LH-015
	LIFT/TILT CYLINDER PIN		LH-016
	HYDRAULIC COOLER		LH-017
			LH-018
			LH-019
	HYDRAULIC HOSE KIT		LH-020
	HOSE – Valve to tilt cylinder forward tee (28")		LH-022
	HOSE – Fwd tee to right cylinder rod end		LH-023
	HOSE – Fwd tee to left cylinder rod end (16")		LH-024
	HOSE – Valve to tilt cylinder rear tee (28")		LH-025
	HOSE – Rear tee to right cylinder clevis (20")		LH-026
	HOSE – Rear tee to left cylinder clevis (9-1/2")		LH-027
	HOSE – Valve to lift cylinder rod end (13")		LH-028
	HOSE – Valve to lift cylinder clevis (19")		LH-029
	HOSE – Valve to gear pump (26")		LH-030
	HYDRAULIC JOYSTICK BOOT		LH-040
	HYDRAULIC JOYSTICK HANDLE		LH-041
	HYDRAULIC JOYSTICK VALVE		LH-042



SECTION X
Hydrostat components parts list

KEY	DESCRIPTION	QTY	PART NUMBER
	PISTON PUMP – REAR		LH-002
	PISTON PUMP –FRONT		LH-005
	FILTER HEAD (2ea)		LH-009
	FILTER (2ea)		LH-010
	WHEEL MOTOR (2ea)		LH-011
	WHEEL MOTOR SHAFT		LH-012
	WHEEL MOTOR SEAL REPAIR KIT		LH-013
	WHEEL MOTOR HOSE (left) 15-1/2" 90& ST		LH-021
	WHEEL MOTOR HOSE (rt) 24" 90&ST		LH-



SECTION XIII
STEERING JOYSTICK ASSEMBLY AND CABLES

	KEY DESCRIPTION	QTY	PART NUMBER
1.	BALL KNOB	1	LSJ-001
2.	HANDLE	1	LSJ-002
3.	BOOT	1	LSJ-003
4.	CLAMP, JOYSTICK BOOT		LSJ-004
5.	ROD END 5/16-24	4	LSJ-005
6.	1/4"-28 ROD END	4	LSJ-006
7.	4 WAY SHIFTER PIVOT BLOCK		LSJ-007
8.	1/4" MALE ROD END w/STUD (4 ea.)		LSJ-008
9.	TAPPED LINKAGE ROD 15" LONG		LSJ-009
10.	5/8" X 1/4" CONTROL LEVER		LSJ-010
11.	1" X 1/4" CONTROL LEVER		LSJ-011
12.	CROSSOVER TUBE		LSJ-012
13.	CROSSOVER TUBE BUSHING (2 ea)		LSJ-013
14.	CROSSOVER SHAFT (5/8 OD)		LSJ-014
15.	TRUNION CONTROL LEVER "A" (1" ID)		LSJ-015
16.	TRUNION CONTROL LEVER "B" (5/8" ID)		LSJ-016
17.	1" ID, 2 BOLT FLANGE BEARING		LSJ-017
18.			LSJ-018
19.	TRUNION LINKAGE ROD "A" (25-1/2"		LSJ-019
20.	TRUNION LINKAGE ROD "B" (16-1/2"		LSJ-020
21.			LSJ-021
22.			LSJ-022



PROPANE TANK 20 lb	LIP-001
PROPANE TANK MOUNT ASSEMBLY	LIP-002
PROPANE TANK MOUNT TOGGLE & NUT	LIP-003
PROPANE TANK ALIGNING PIN	LIP-004
PROPANE QUICK COUPLER	LIP-005
PROPANE FITTING ¼" MPT x 5/16" hose end	LIP-006
PROPANE HOSE, Tank to bulkhead 12"	LIP-007
PROPANE BULKHEAD	LIP-008
PROPANE HYDROSTATIC RELIEF VALVE	LIP-009
PROPANE HOSE, Bulkhead to lock-off solenoid	LIP-010
PROPANE FITTING, 5/16" hose end x 3/8" flare	LIP-011
PROPANE FITTING, ¼" MPT x 3/8" Flare 90	LIP-012
PROPANE LOCK-OFF SOLENOID	LIP-013
PROPANE FITTING ¼" MPT X 1/4" FPT 45	LIP-014
PROPANE VAPORIZER	LIP-015
PROPANE HOSE, Vaporizer to regulator 8"	LIP-016
PROPANE REGULATOR T-60	LIP-017
PROPANE MOUNTING BRACKET	LIP-018
PROPANE VAPOR HOSE, regulator to load block	LIP-019
PROPANE LOAD BLOCK	LIP-020
KIT, VAPORIZOR REPAIR KIT	LIP-021
KIT, REGULATOR REPAIR KIT	LIP-022

