



The Chemical Company

PRODUCT DATA

9 09678

Quartz
Flooring

UCRETE® HP AND HP/Q

Polyurethane-concrete slurry broadcast floor-resurfacing systems

Description

Ucrete® HP and HP/Q are three-component polyurethane-concrete systems with a broadcast aggregate. Both of these systems are installed at a finished thickness of 1/4 – 3/8" (6 – 9 mm). The thickness is determined by the service and cleaning temperatures and the severity of traffic expected. Ucrete® HP/Q uses a colored quartz aggregate to yield a textured surface. Ucrete® HP uses a translucent quartz aggregate. Ucrete® floors are extremely tough and have many physical properties that exceed those of typical concrete.

Yield

For coverage rates, refer to the Ucrete® Contractor Installation Guideline.

Packaging

Parts 1 and 2: 1 gallon (3.79 L) cans, filled to provide the proper ratio
Part 3: 54 lb (24.5 kg) bags

Colors

Ucrete® HP: red, gray, cream, and charcoal.

Ucrete® HP/Q: Blended quartz colors: green, red, gray, and cream.

Features

- Slip-resistant finish
- Thermal stability
- Two-step application
- Solvent free
- No priming or sealing of substrate
- 30 years of project references
- Unaffected by freeze-thaw cycles
- Excellent impact and abrasion resistance
- Extremely high bond strength
- Chemical resistant
- Can be applied to 7 – 10 day old concrete
- Wide temperature service range from -50 to 210° F (-45 to 100° C)
- Slip-resistant finish
- Coefficient of thermal expansion similar to concrete

Benefits

- Improved safety, especially in wet areas
- Takes continuous hot-water cleaning
- 48-hour installation time
- Low odor; VOC compliant
- Speeds application time
- Proven track record
- Handles wide temperature fluctuations
- Handles heavy traffic
- Reduces shear at bond line
- Tolerates organic and inorganic acids, alkalis and salts
- Accelerates work schedules
- Exceeds that of typical epoxy overlays
- Meets ADA recommendations
- Prevents shear at bond line

Shelf Life

Parts 1 and 3: 6 months when properly stored
Part 2: 1 year when properly stored

Storage

Store and transport in unopened containers in a clean, dry area at stable temperatures approximating 60 to 73° F (15 to 22.5° C).

Where to Use

APPLICATION

- Where severe conditions exist—high impact pressure, thermal shock, and chemical exposure
- Where aesthetics are a consideration
- On severely damaged surfaces
- Wet conditions requiring a heavily textured slip-resistant surface

- Where steam or hot water is required for cleaning
- Meat, poultry, and dairy plants
- Bottling facilities
- Pharmaceutical plants
- Commercial kitchens and restaurants
- Freezers and refrigerated storage areas
- Food packing and canning plants

LOCATION

- Interior applications

SUBSTRATE

- Over new and existing concrete surfaces and toppings; when applying over other substrates, contact BASF Technical Service



Technical Data

Composition

Ucrete® HP and HP/Q are three-component polyurethane-concrete systems incorporating a broadcast lock coat.

Compliances

- USDA accepted for use in federally inspected meat and poultry plants in the USA
- Ministry of Agriculture, Canada, accepted for use in food establishments in Canada
- British Standard Specifications (BSS), for use in the U.K.
- Meets ADA recommendations for a slip-resistant surface

Test Data

PROPERTY	RESULTS	TEST METHODS
Compressive strength , psi (MPa)	8,128 (56)	ASTM C 579
Tensile strength , psi (MPa)	880 (6.0)	ASTM C 307
Coefficient of thermal expansion , in/in/° F (cm/cm/° C)	2.7 x 10 ⁻⁶ (1.5 x 10 ⁻⁵)	ASTM C 531
Density , lb/ft ³ (g/cm ³)	130 (2.08)	ASTM C 905
Resistance to fungi growth	Passes, rating of one	ASTM G 21
Impact resistance	No visible damage or deterioration at minimum 160 in-lb	ASTM D 2794
Compressive modulus , psi (MPa)	1.7 x 10 ⁵ (1,170)	ASTM C 469
Flexural strength , psi (MPa)	2,325 (16)	ASTM C 580
Modulus of elasticity , psi (MPa)	1.7 x 10 ⁵ (1,170)	ASTM C 469
Thermal conductivity , BTU-in/in-ft ² °F (W/mK)	6.78 (1.0)	ASTM C 177
Water absorption , %	< 0.1	ASTM C 413
Abrasion resistance , g loss; CS-17 Wheel, 1,000 cycles	0.07	ASTM D 4060
Resistance to elevated temperatures	No flow or softening	MIL-D-3134
Adhesion , psi (MPa)	400 (2.8) 100% concrete failure	ASTM D 4541
Coefficient of friction , wet and dry	Passes ADA recommendations	ASTM D 2047

Chemical Resistance

In accordance with ASTM D 1308, Ucrete® HP and HP/Q will resist exposure for up to 7 days at 72° F (22° C) for the following chemicals.

- Dilute mineral acids including hydrochloric (< 35%), phosphoric (< 50%), and sulfuric (< 30%)
- Alkalis, including potassium hydroxide to a 50% concentration
- Some dilute organic acids such as acetic (30%), formic, citric, and uric
- Fats, oils, and sugars
- Mineral oils, diesel fuel, kerosene, and gasoline
- Most organic solvents, including aliphatic and aromatic hydrocarbons and alcohol

NOTE: Full chemical resistance is achieved after curing for 7 days. For chemical resistance to a specific compound, consult the Ucrete® Chemical Resistance Guide. Contact your BASF representative for more information.

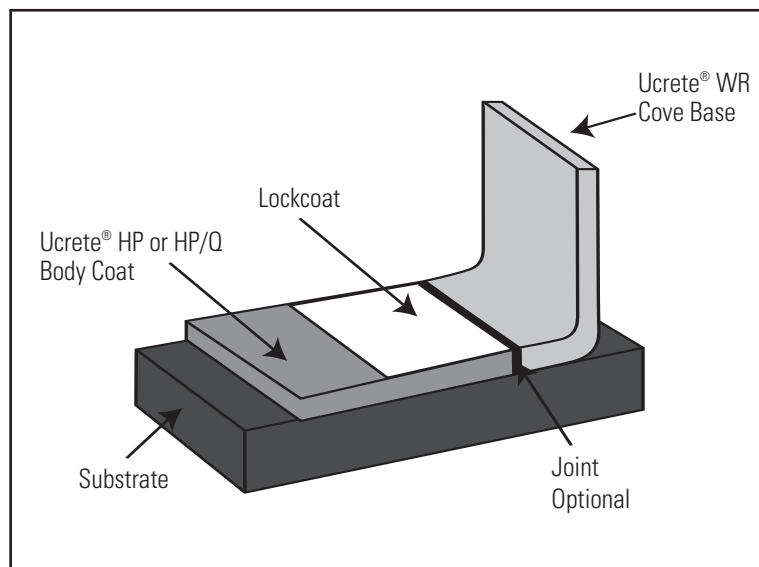

How to Apply

Ucrete® floor, deck, and wall systems are installed by approved contracting firms who have completed the manufacturer's training workshops. Ucrete® is a globally branded product line with industry synergies around the world.

The following is only a summary of the installation techniques used by your Ucrete® approved contractors. Refer to the Ucrete® Contractor Installation Guideline for more information.

Surface Preparation

1. Floors must be structurally sound and properly cured. Test floor for vapor drive in accordance with ASTM D 4263.
2. Repair concrete as necessary.
3. Use a commercial degreaser to clean floors of oil, grease, and other bond-inhibiting materials.
4. Remove curing and parting compounds and other surface hardeners and floor coatings in accordance with the manufacturer's instructions.
5. Mechanical surface profiling is the method of surface penetration for both new and existing floors. Mechanically profile the floor to a minimum CSP 4-5 as described by the International Concrete Repair Institute.
6. Apply a 10 by 10 ft (3 by 3 m) test in an inconspicuous area that meets the owner's expectations for appearance, slip resistance, and performance.

Application

1. Install Ucrete® WR cove base, as required. Refer to the Ucrete® Contractor Installation Guideline for details.

2. Mix the 3 components of Ucrete® HP or HP/Q using a mechanical mixer. The materials are supplied in pre-measured containers.
3. Screed or trowel apply the mixed material at 3/16 – 1/4" (4 – 6 mm) thick onto the floor. Back roll with a loop and spike roller to level the body coat to the specified thickness, allowing the applied material to settle. Immediately broadcast the specified aggregate into the wet mix. Apply the aggregate beyond the point of rejection or 1.5 lbs/ft² (7.3 kg/m²).
4. Allow a minimum of 8 hours for the Ucrete® to cure, then sweep, stone, and vacuum excess aggregate to achieve the desired profile.
5. Apply the required clear or pigmented finishing coat to lock in the aggregate and obtain the desired profile. The total system thickness should range from 1/4 – 3/8" (6 – 9.5 mm), depending on the job requirements.

Drying Time

The floor can be returned to full service after 24 hours at 70° F (21° C) following the lock-coat application. Do not expose Ucrete® HP and HP/Q to any chemicals until fully cured (12 hours at 70° F [21° C]). In colder climates with temperatures below 50° F (10° C), it may take as long as 48 hours to reach full operational strength. Allow 7 days for full chemical cure of lock coat.

Maintenance

Regular cleaning and maintenance will prolong the life of all polymer flooring systems, enhance their appearance, and reduce any tendency to retain dirt. Ucrete® will withstand high-pressure or hot-water washdowns (2,500 psi [17.2 MPa] at 180° F [82° C]), along with a wide range of decontamination and degreasing materials.

For Best Performance

- The owner and architect should discuss joint details with the flooring contractor before the job starts.
- Use an effective moisture barrier for substrates on or below grade; if not present, consult your BASF representative for options.
- Substrates must be structurally sound, clean, dry, and free of any foreign matter that could inhibit adhesion.
- Do not apply at temperatures below 50° F (10° C) or above 85° F (29° C) or if the relative humidity is above 85%.
- Do not apply directly to unreinforced sand-cement screeds, asphalt or bitumen substrates, glazed tile or nonporous brick and tile, magnesite, copper, aluminum, existing coatings, epoxies, or polyesters. For optimal performance, apply directly to concrete. Consult with your Ucrete® representative for advice.
- Ucrete® HP and HP/Q are designed for a two-step application. Variations in thickness will affect the system's thermal and impact resistance. Thicker systems will provide the highest level of thermal shock and impact resistance, especially when used in conjunction with Ucrete® HF.
- Build coves and vertical surfaces with Ucrete® WR. Contact BASF Technical Service for details.
- BASF representatives and flooring specialists are available to assist you in the selection of the proper flooring system. Call 1-800-243-6739 for in-house and field technical assistance.
- Make certain the most current versions of product data sheet and MSDS are being used; call Customer Service (1-800-433-9517) to verify the most current versions.
- Proper application is the responsibility of the user. Field visits by BASF personnel are for the purpose of making technical recommendations only and not for supervising or providing quality control on the jobsite.

Health, Safety and Environmental

Read, understand and follow Material Safety Data Sheets and product labels for all components of this flooring system prior to use. The MSDS can be obtained by searching for them on www.BuildingSystems.BASF.com, e-mailing your request to basfbcsst@basf.com or calling 800/433-9517. Use only as directed.

**BASF Construction Chemicals, LLC –
Building Systems**

889 Valley Park Drive
Shakopee, MN, 55379

www.BuildingSystems.BASF.com

Customer Service 800-433-9517
Technical Service 800-243-6739



LIMITED WARRANTY NOTICE Every reasonable effort is made to apply BASF exacting standards both in the manufacture of our products and in the information which we issue concerning these products and their use. We warrant our products to be of good quality and will replace or, at our election, refund the purchase price of any products proved defective. Satisfactory results depend not only upon quality products, but also upon many factors beyond our control. Therefore, except for such replacement or refund, **BASF MAKES NO WARRANTY OR GUARANTEE, EXPRESS OR IMPLIED, INCLUDING WARRANTIES OF FITNESS FOR A PARTICULAR PURPOSE OR MERCHANTABILITY, RESPECTING ITS PRODUCTS,** and BASF shall have no other liability with respect thereto. Any claim regarding product defect must be received in writing within one (1) year from the date of shipment. No claim will be considered without such written notice or after the specified time interval. User shall determine the suitability of the products for the intended use and assume all risks and liability in connection therewith. Any authorized change in the printed recommendations concerning the use of our products must bear the signature of the BASF Technical Manager.

This information and all further technical advice are based on BASF's present knowledge and experience. However, BASF assumes no liability for providing such information and advice including the extent to which such information and advice may relate to existing third party intellectual property rights, especially patent rights. In particular, BASF disclaims all **CONDITIONS AND WARRANTIES, WHETHER EXPRESS OR IMPLIED, INCLUDING THE IMPLIED WARRANTIES OF FITNESS FOR A PARTICULAR PURPOSE OR MERCHANTABILITY, BASF SHALL NOT BE RESPONSIBLE FOR CONSEQUENTIAL, INDIRECT OR INCIDENTAL DAMAGES (INCLUDING LOSS OF PROFITS) OF ANY KIND.** BASF reserves the right to make any changes according to technological progress or further developments. It is the customer's responsibility and obligation to carefully inspect and test any incoming goods. Performance of the product(s) described herein should be verified by testing and carried out only by qualified experts. It is the sole responsibility of the customer to carry out and arrange for any such testing. Reference to trade names used by other companies is neither a recommendation, nor an endorsement of any product and does not imply that similar products could not be used.

For professional use only. Not for sale to or use by the general public.

Form No. 1025789 10/09

Printed on recycled paper including 10% post-consumer fiber.

© 2009 BASF
Printed in U.S.A.